

P/N: MR160

Copyright

© 2017, FLIR Systems, Inc.

All rights reserved worldwide. Names and marks appearing herein are either registered trademarks or trademarks of FLIR Systems and/or its subsidiaries. All other trademarks, trade names or company names referenced herein are used for identification only and are the property of their respective owners.

Document identity

Publ. No.: MR160

Release:

Commit: 42566

Language:

Modified: 2017-05-09

Formatted: 2017-05-09



FLIR MR160: Imaging Moisture Meter	
Part number	MR160
Part name	Imaging Moisture Meter with IGM

The FLIR MR160 Imaging Moisture Meter is the first of its kind. Equipped with a built-in thermal camera, the FLIR MR160 is the only moisture meter with the power to show you exactly where to measure. Featuring Infrared Guided Measurement (IGM) technology, the FLIR MR160 helps you quickly scan and target moisture issues, visually guiding you to the spot where you can confidently take measurements and analyze readings.

An integrated pinless sensor and an external pin probe provide the flexibility to take either intrusive or non-intrusive measurements. Built tough with an industry-leading warranty, the FLIR MR160 can serve as your go-to troubleshooting tool right out of the box—or as the perfect complement to any high-resolution thermal camera you already own—helping you find hidden moisture issues and capture reliable data more efficiently.

Identify and verify with one tool—the first-ever thermal imaging moisture meter:

- 80 × 60 Lepton thermal imager powers IGM technology.
- Document thermal images and moisture readings on one screen.
- Review images and generate reports with free FLIR Tools software.

Troubleshoot quickly—easily investigate insulation and moisture issues:

- Pinless technology for fast non-intrusive measurements.
- External pin probe included for contact moisture measurements.
- Easy targeting with the laser pointer and display cross-hairs.

Portable, tough and durable—drop-tested rugged design:

- Industry-leading warranty.
- Small form factor to conveniently carry with you.
- Internal rechargeable battery with USB.

Thermal imaging	
Imaging detector	FLIR Lepton, microbolometer focal plane array
Shutter	Integrated automatic shutter for auto flat field correction
Thermal image resolution (H × W)	4800 pixels (80 × 60)
Spectral response	8–14 μm
Field of view (horizontal × vertical)	51° × 38°
Upper scene range	127°C (260°F, 400 K)
Sensitivity	<150 mK

P/N: MR160

© 2017, FLIR Systems, Inc.

#MR160; r. /42566;

Thermal imaging	
Image update speed frequency	9 Hz
Thermal image palettes	Ice
Thermal image minimum focus distance	10 cm (4")
Moisture measurement	
Pin moisture via external probe range (accuracy)	0–100% WME ± 5%
Pin moisture groups	9 material groups
Pinless moisture range	0–100 relative measurement
Pinless moisture depth	1.9 cm (0.75") maximum
Sample rate	10 Hz (approximate, both modes)
Measurement resolution	0.1
Response time—pinless	100 ms
Response time—pin mode	750 ms
General information	
Display type (W × H)	QVGA (320 × 240 pixels), 2.3", 64 000 color, TFT graphical display
Warranty	2 years product, 10 years thermal imaging detector
Saved image file format	BMP with measurement values overlaid
Stored image capacity	9999 images
Internal memory	4 GB
Laser	
Type	Visible class 2
Orientation	Single laser pointer to center of thermal image
Power output	1.0 mW (maximum)
Wavelength	650 ± 20 nm
Certifications	
Certification standards	EN61326 (EMC), EN61010 (battery, charger), EN60825-1 Class 2 (laser)
Agency approvals	CE, FCC Class B, RCM
Power system	
Power requirements	Integrated rechargeable battery
Continuous run time	18 hours maximum
Typical usage	4 work weeks
Auto power off	Programmable: off, 1, 5, or 20 minutes
Power adapter	100–240 V input/ 5 V 1 A output
Battery	3.7 V, 3000 mAh Li ion rechargeable via micro USB
Environmental specifications	
Drop test	3 m (9.8')
IP rating	IP54 dust-protected and splash-resistant
Operating temperature	0–50°C (32–122°F)
Storage temperature	–10 to +60°C (+14 to +140°F)



FLIR MR160

P/N: MR160

© 2017, FLIR Systems, Inc.

#MR160; r. /42566;

Environmental specifications	
Operating humidity	≤90%, 0–30°C (32–86°F) ≤ 75%, 30–40°C (86–104°F) ≤ 45%, 40–50°C (104–122°F)
Storage humidity	90% relative humidity
Meter physical data	
Weight:	300 g (10.6 oz.)
Dimensions (H × W × L)	14 cm × 7.2 cm × 4.2 cm (5.5" × 2.9" × 1.7")
Material	PC-ABS
Color	Gray, black
Shipping information	
Packaging type	Retail color box
Packaging contents	MR160, MR02 pin probe, quick start guide, international charger, warranty card, brochure cCard
Packaging weight	0.91 kg
Packaging dimensions (L × W × H)	12.1 cm × 14 cm × 33.1 cm
Inner carton quantity	4
Inner carton weight	4.1 kg
Inner carton dimensions (L × W × H)	26.7 cm × 61 cm × 15.9 cm
Master carton quantity	12
Master carton weight	13.3 kg
Master carton dimensions (L × W × H)	64 cm × 25.8 cm × 51.2 cm
EAN-13	0793950371602
UPC-12	793950371602
Country of origin	China
Tariff code	9025805000
Accessories	
MR10	EVA Protective Case
MR05	Impact Pin Probe
MR05-PINS1	Replacement Pins for MR05
MR05-PINS2	Replacement Pins for MR05 (wide)

© 2015, FLIR Systems, Inc. All rights reserved worldwide. No part of this drawing may be reproduced, stored in a retrieval system, or transmitted in any form, or by any means, electronic, mechanical, photocopying, recording, or otherwise, without written permission from FLIR Systems, Inc. Specifications subject to change without further notice. Dimensional data is based on nominal values. Products may be subject to regional market considerations. License procedures may apply. Product may be subject to US Export Regulations. Please refer to exportquestions@flir.com with any questions. Diversion contrary to US law is prohibited

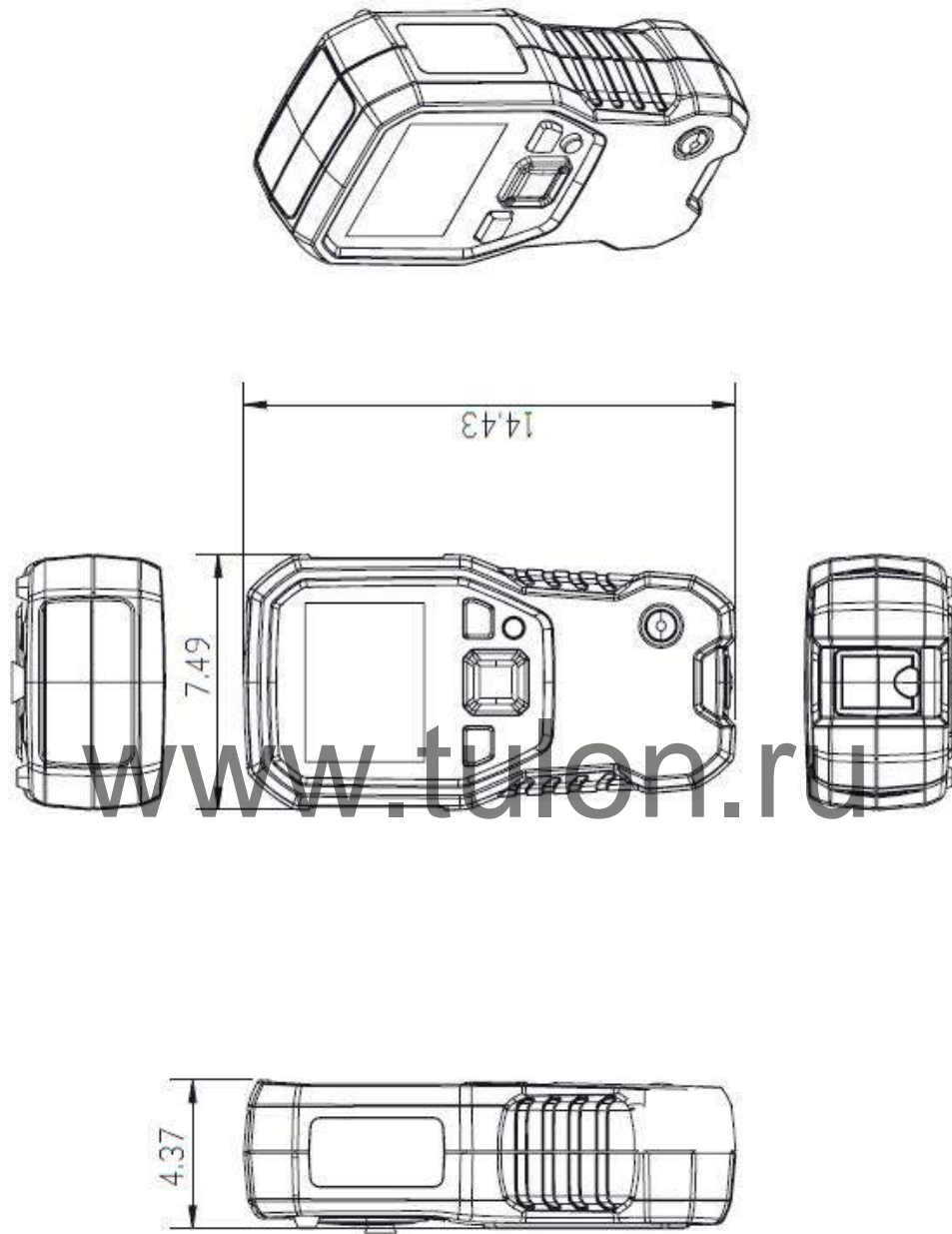

Modified Date Thursday, April 23, 2015	Modified By T&M Engineering
Description FLIR MR160 Imaging Moisture Meter	
Units Centimeters	Scale Not to Scale